

Bench Testing Stonel 35 Solid State Sensors

WARNING:

DO NOT BENCH TEST STONEL SST SOLID STATE SENSORS WITHOUT A SERIES LOAD RESISTOR. THIS MAY RESULT IN PERMANENT DAMAGE TO THE SENSOR.

Stonel's SST sensors are 2-wire AC/DC solid state sensors. Operating voltage is: 8-250VDC and 20-250VAC Max. Sensors are not polarity sensitive. Current flow through the sensors must not be allowed to exceed 100mA Max. for normal operation.

Stonel solid state sensors cannot be tested with an ohmmeter. A current limited power source is required to test for sensor operation/setting of limit switches.

All Stonel SST sensors have indicating LEDs. The bottom/closed sensor has a red LED. The top/open sensor has a green LED.

Connect SST sensor as per schematic below with correct size resistor based on voltage being applied (refer to load table below). Sensor Commons and NO/NC's can be jumpered together to power both sensors for testing/setting. Adjust cam or trigger so that the LED lights at desired valve position.

Once sensor operation has been verified, unit can now be placed into service. Neither the series load resistor or an external power source is required for field operation. The power and series load for the sensor is provided by the discrete input card of the control system.

Voltage	Resistor Value	Resistor Wattage
9 Volts	0.5K - 1.5K	0.25 Watt
12 Volts	0.5K - 2.0K	0.25 Watt
24 Volts	1.0K - 4.0K	0.5 Watt
120 Volts	15K - 20K	1.0 Watt
250 Volts	30K - 40K	2.5 Watt

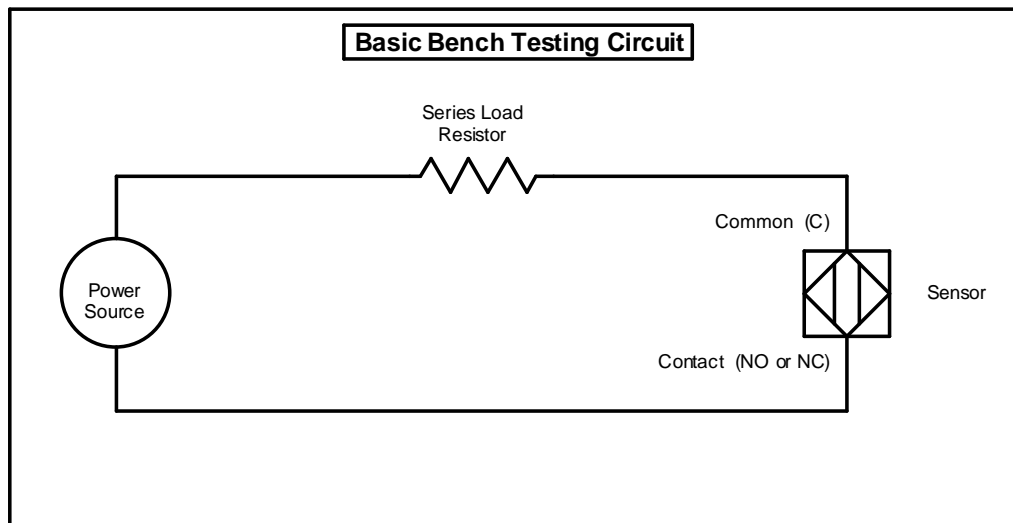

NOTE

Bench testing of Stonel solid state sensors with a 4-20mA loop calibrator does not require the use of a series load resistor.

NOTE

Having the 4-20mA loop calibrator set at maximum current output will provide brighter LED Indication.

Stonel solid state sensors cannot be tested with an ohmmeter. A current limited power source such as a 4-20mA loop calibrator can be used to power the sensors to verify operation and the setting of limit switches.

All Stonel made solid state sensors have indicating LEDs. The closed sensor has a red LED and the open sensor has a green LED.

Connect the 4-20mA loop calibrator to the sensor module per the drawing below. Sensor Commons (C) and NO's should be jumpered together to power both sensors for testing/setting. Press the Set Open/Set Closed pushbuttons or adjust cams or triggers so that the proper LED is on at each desired valve position.

Once sensor operation has been verified unit can be placed into service. When placed into service, the power for the sensors is provided by the discrete input card of the control system.

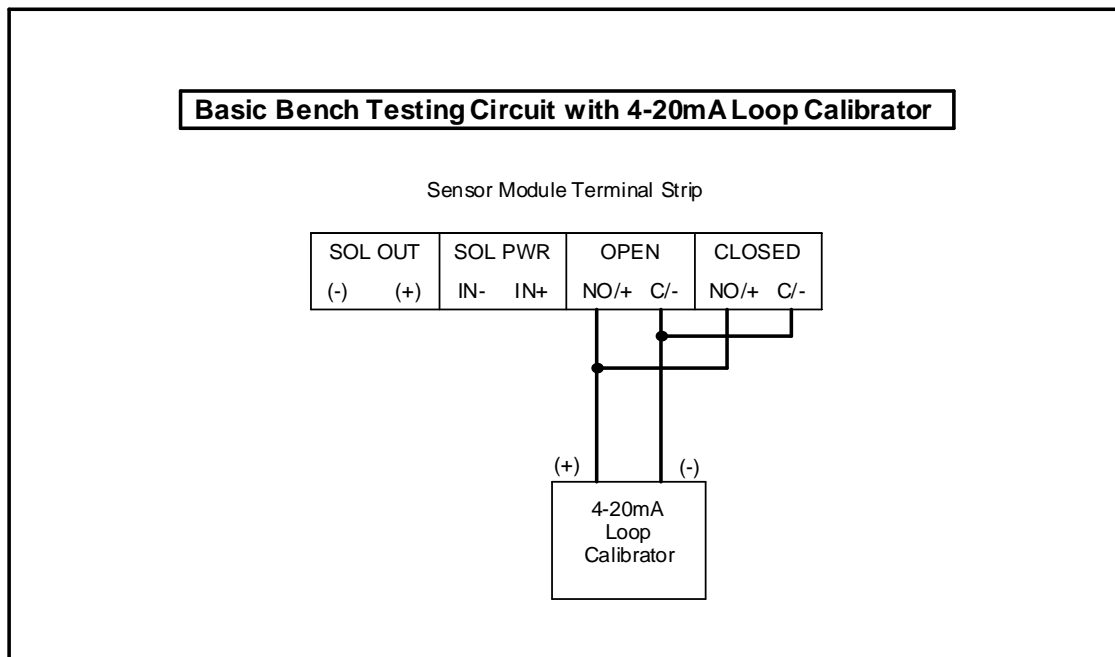

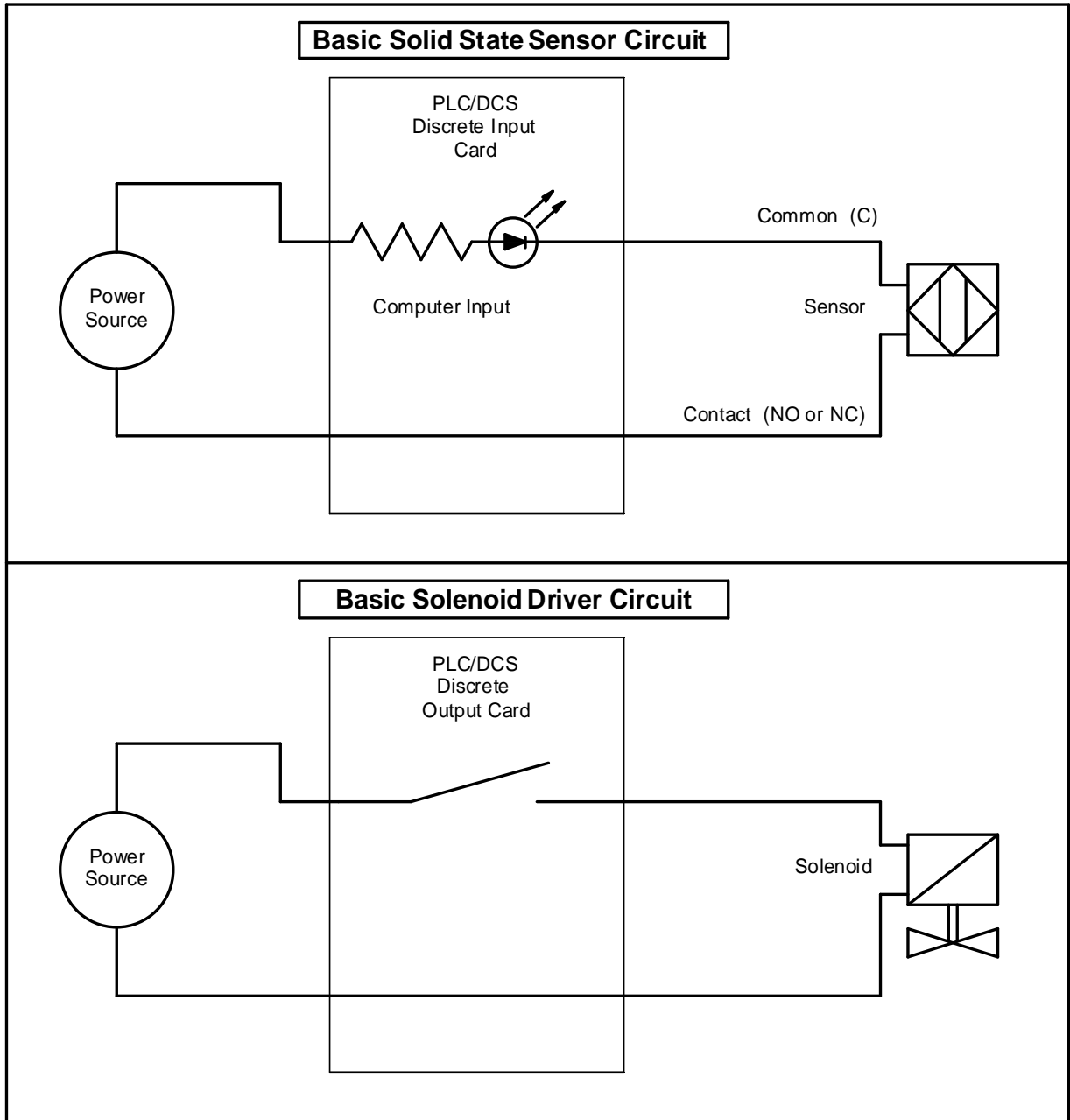

Typical Basic Intrinsically Safe Circuit with Namur Sensor

