

Valmet Breast Roll Shaker for improved formation

Executive Summary

Valmet Breast Roll Shaker improves the sheet forming process. Valmet Breast Roll Shaker shakes the breast roll cross-directionally and breaks up fiber flocks by creating shear forces on the web. This system improves sheet formation, and strength and visual properties.

Valmet Breast Roll Shaker is very easy to use: simply set the frequency and stroke length then press the start button on the control panel. Valmet Breast Roll Shaker is designed for easy upkeep with few parts needing maintenance. Valmet Breast Roll Shaker has a very compact design and all equipment is integrated into one unit.

Valmet Breast Roll Shaker has proven itself on uncoated and coated woodfree, kraftliner, sack paper, liquid packaging board, recycled linerboard and multi-layer grades. Results on board machines show an average formation improvement of 15%. Most recently, a North American reference has seen a 20% improvement in formation with a corresponding 11% gain in bottom side smoothness.

Valmet Breast Roll Shaker breast roll shaker improves formation

Valmet Breast Roll Shaker is Valmet's solution for improving the sheet forming process. Valmet Breast Roll Shaker shakes the breast roll cross-directionally and breaks up fiber flocks and enhances fiber orientation by creating shear forces on the web. This system improves sheet formation as well as strength and visual properties.

Improved formation and low power consumption

Valmet's self-balanced breast roll shaker provides important benefits that will improve formation. And good formation allows the mill to optimize their furnish.

- Permits the use of lower quality furnish
- Optimization of the amount of filler
- Optimization of beating rate (less beating)
- Basis weight for multi-ply machines may be decreased for raw material savings in the top layer



Figure 1. Valmet Breast Roll Shaker improves formation with low power consumption.

Other benefits provided by Valmet Breast Roll Shaker include:

- Improved strength properties
- Better printability and smoother surface
- Improved, even formation also provides
 - less calendering needed, no bulk lost
 - even retention and enhanced dewatering
- Lower MD/CD tensile ratio
- Better runnability in press and dryer sections, especially in edge areas
- Plug and play installation
- Low power consumption, only one electric drive

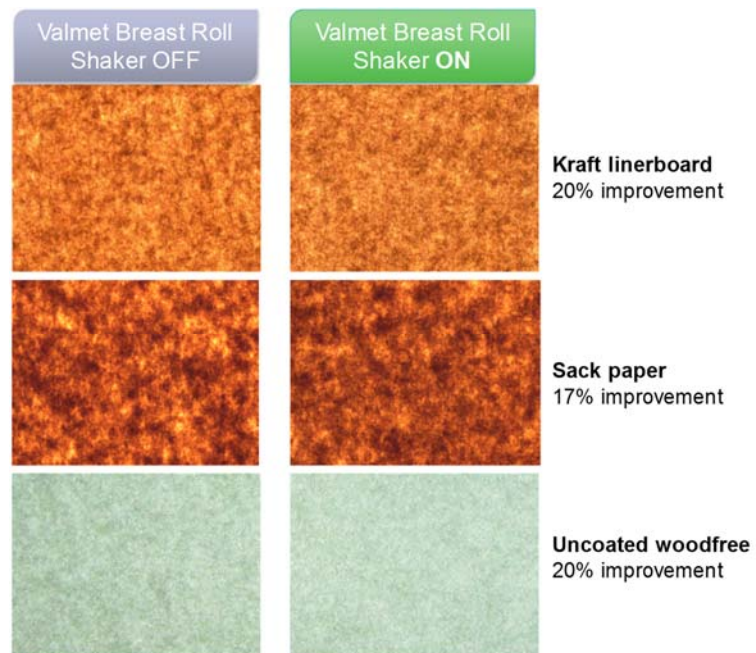

Figure 2. Results show an average increase in formation of 15-20% depending on grade.

How does it work?

Valmet Breast Roll Shaker shakes the breast roll with the help of rotating eccentric mass pairs. These eccentric mass pairs are connected to a slide which in turn is connected to the breast roll. The frequency and amplitude of shaking can be individually adjusted.

Valmet Breast Roll Shaker is mounted on a concrete or steel foundation at the back side of the breast roll. Installation on the front side is also possible if it does not interfere with fabric replacement.

The breast roll shaking force is created by the rotating eccentric mass pairs. The unit houses two mass pairs. One pair creates the primary shaking force while the second serves as a control pair that creates a counterforce to the primary shaking force. The actual shaking force is adjusted by altering the phase shift between the two mass pairs. When the phase shift between the mass pairs is 180 degrees, no shaking force is created and all forces remain inside the unit.

The mass pairs are fixed to a slide that moves on a film of hydraulic oil inside the shaker housing and no reaction forces are therefore conveyed to the foundation. A connecting rod connects the internal slide to the breast roll shaft. The connecting rod is bearing mounted and its purpose is to transfer the shaking force to the rotating breast roll shaft.

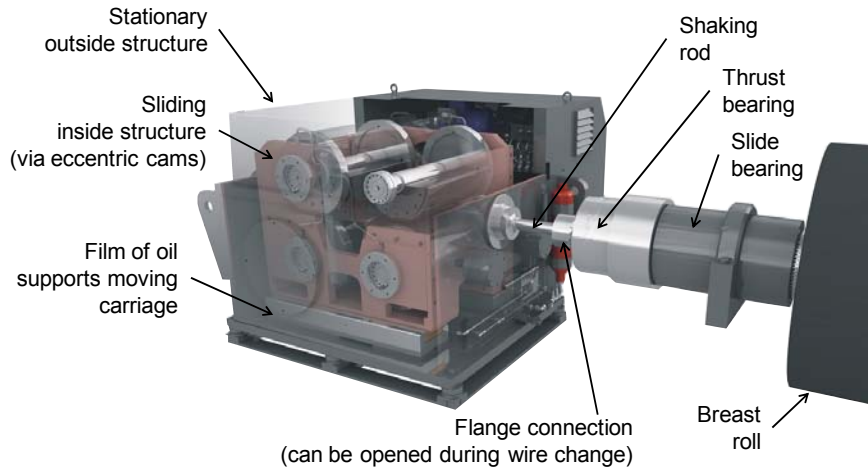

Figure 3. Valmet Breast Roll Shaker's compact design uses balanced eccentric mass pairs to shake the breast roll in the cross-direction.

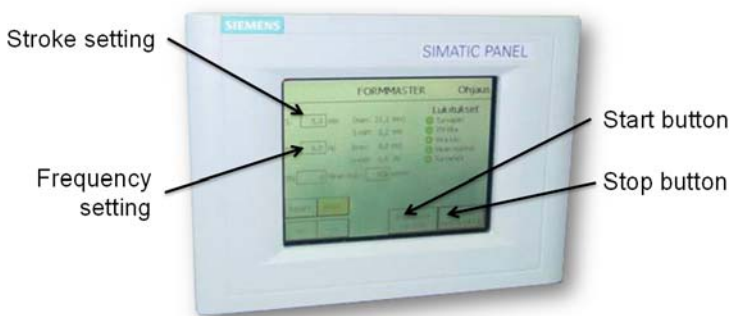

Figure 4. Valmet Breast Roll Shaker is easy to use; just two values to set then press Start.

mechanically between the primary and secondary drive shaft. The unit thus has only one drive motor. All controls are automatically self-resetting in the event of power failures. The longer stroke provided by Valmet Breast Roll Shaker allows for quality optimization.

Easy to use

Valmet Breast Roll Shaker is very easy to use: simply set the frequency and stroke length then press the start button on the control panel.

Stroke frequency is adjusted by controlling the speed of the unit's electric drive motor by means of a frequency converter.

Stroke amplitude is controlled as a function of the shaking force by adjusting the phase shift between the mass pairs. This phase shift is adjusted

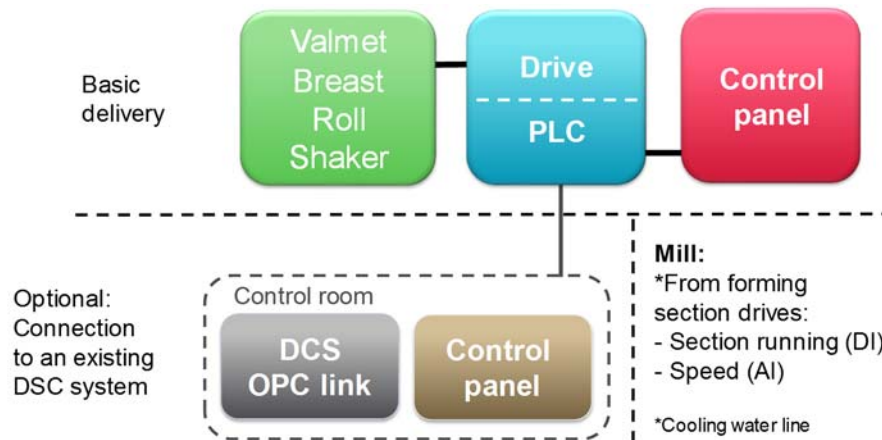

Figure 5. Valmet Breast Roll Shaker is easy to use, with just two values to set and then press Start.

Easy to maintain

Valmet Breast Roll Shaker is designed for easy upkeep with few parts needing maintenance. Linear rails provide reliable and accurate carrier movement. The control system with programmable logic controller (PLC) makes Valmet Breast Roll Shaker a real "plug and play" system. The mechanical construction is reliable and simple when compared to

other shakers which require two electric motors. The couplings are easy to change. The integrated gearbox uses a hydraulic actuator. Phase angle control is provided by a simple proportional valve so no programming is needed. Control system options include Allen Bradley, Valmet DNA and Siemens.

Safe compact design

Valmet Breast Roll Shaker has a very compact design and all equipment is integrated into one unit. It has only one electric drive and thus low power consumption. The simplified design needs less space and includes fewer parts. A standard commercial motor is used, and all parts are readily available. Valmet Breast Roll Shaker fits in most machine environments.

Thanks to the ingenious Valmet Breast Roll Shaker design, there is no damage to equipment or the environment in a power cut situation. In the event of loss of power the stroke length is reset to zero, resulting in no internal or external damage. The torque motor lines include a pressure accumulator and two safety valves, which provide for a fast and safe shutdown of Valmet Breast Roll Shaker in the event of a loss of power for forming section emergency stop. Valmet Breast Roll Shaker uses spring centering, rather than centering via a linear motor which has an electromagnetic field that imposes a health risk for employees.

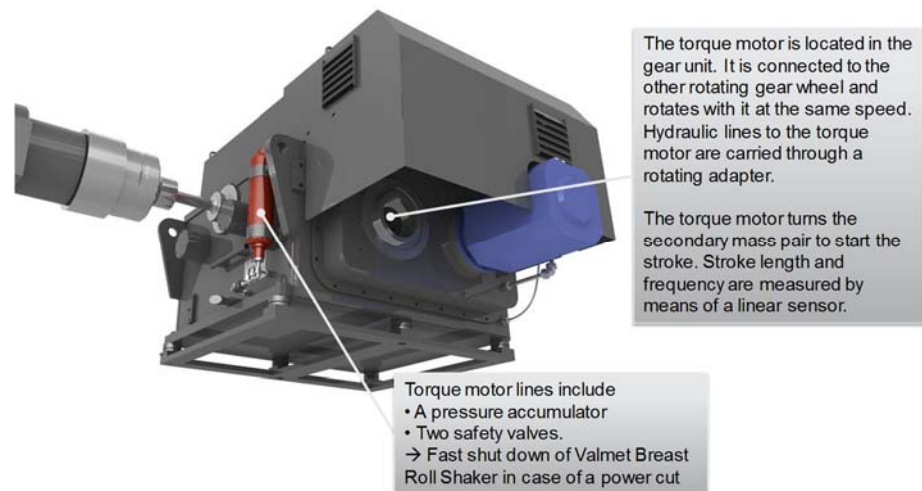

Figure 6. Phase angle is shifted using a directional proportional valve.

Typical installation scope

The typical delivery package most mills choose includes the Valmet Breast Roll Shaker unit assembled with pre-piping with all necessary automation parts, frequency converter and shaking rod. A test run is

performed. As an option steel supports are available. Some mills prefer to replace the breast roll with a composite roll in those cases where the breast roll is too heavy and will limit the Valmet Breast Roll Shaker operating parameters (frequency and stroke). The breast roll is provided with slide bearings and oil lubrication and the breast roll's lifting arm is modified as needed.

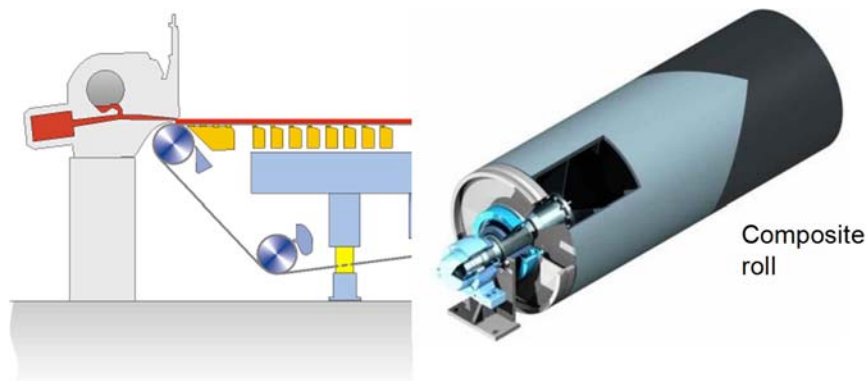

Figure 7. The breast roll may be replaced with a composite roll.

Proven results worldwide

With many references over several years, Valmet Breast Roll Shaker has proven itself on uncoated and coated woodfree, kraftliner, sack paper, liquid packaging board, recycled linerboard and multi-layer grades. Mills trust Valmet Breast Roll Shaker to provide results, and after success with their first unit, it's common for mills to make repeat orders for sister machines.

"No one else is producing such good quality sack paper," says one mill director. He continues, "We haven't had any quality complaints from our customers. Such successful results have been possible due to Valmet's equipment and technology." In addition to improved formation, mills report better printability, enhanced dewatering, lower strength MD/CD ratio, increased smoothness, higher burst, improved stiffness MD/CD ratio, better air permeability and increased production.

Results on board machines show an average formation improvement of 15%. Most recently, a North American reference has seen a 20% improvement in formation with a corresponding 11% gain in bottom side smoothness.

Case Study – Long term partnership provides results

Valmet supplied JSC Segezha Pulp and Paper Mill in Russian Karelia with an extensive rebuild of their PM 9 production line for extensible sack kraft paper. The rebuilt production line started up in summer 2008.

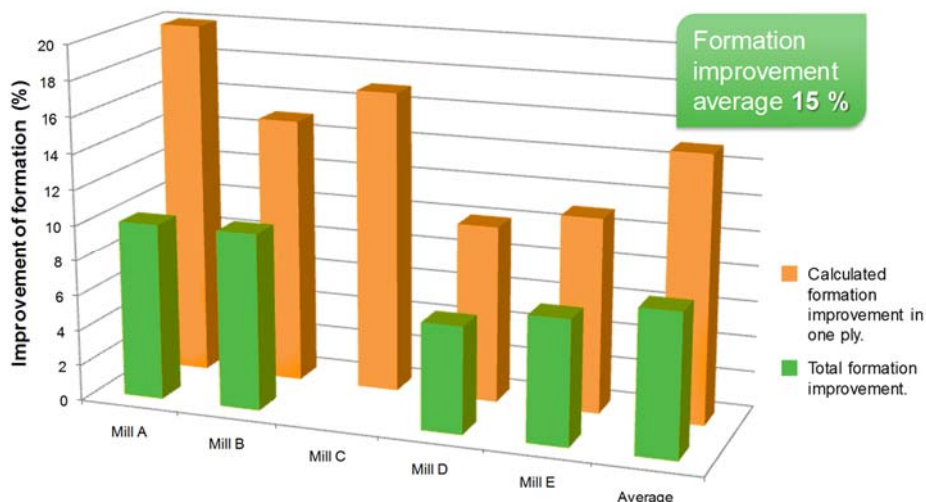

Figure 8. The average formation improvement for board machines is 15% with Valmet Breast Roll Shaker.

The Segezha Pulp and Paper Mill is located in northwestern Russia in the Republic of Karelia, about 700 km north of St Petersburg. Segezha, which is owned by the InvestLesProm Group, is the only Russian manufacturer of semi-extensible sack paper. The PM 9 rebuild strengthened Segezha's position in the industry and provided the paper sack factories of Segezha Packaging with good-quality paper. Together with a rebuild of PM 10, also carried out by Valmet, the modernization of PM 9 increased Segezha's annual capacity of semi-extensible sack paper to 250,000 tons. The 7.1-meter-wide PM 9 is a sack paper machine that was originally delivered by Valmet (Valmet) in 1972. The rebuild allowed a potential increase of the machine's production speed to 750 m/min and a daily capacity of 550 tons. But speed and capacity were not the primary objectives: "The main target was quality improvement," says Vladimir Ermakov, Executive Director of JSC Segezha Pulp and Paper Mill.

Long-term cooperation

The Segezha Pulp and Paper Mill selected Valmet as a result of good experience gained in the high-consistency refining project of 2002 and subsequent modernization of PM 10 and stock preparation by Valmet in 2004. "We have been working with Valmet for a long time now. A total mutual understanding has been reached during our collaboration. All questions have been solved very fast and decisions have been taken promptly," says Vladimir Ermakov. "A supplier's credibility forms the basis of a successful project. We have already had work experience with Valmet so, as the saying goes, if it ain't broke don't fix it! We were already familiar with the technology and operation mechanism so this enabled us to avoid the challenges we faced during the modernization of PM 10."

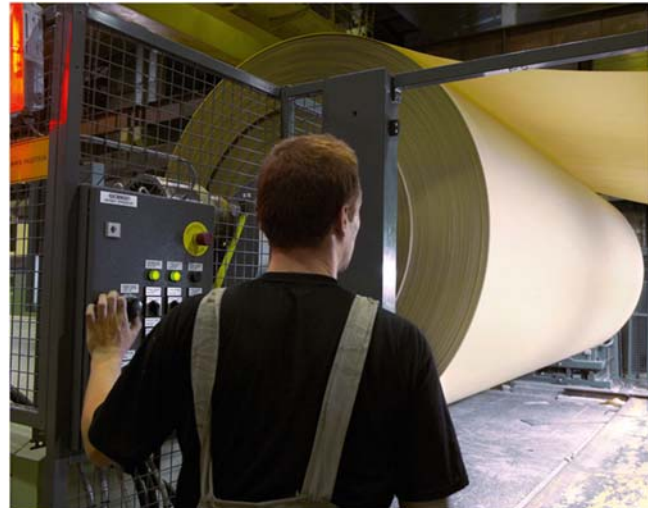

Figure 9. PM9 produces sack kraft paper and was rebuilt in 2008.

Rebuild project tasks and scope

The first steps in the project were taken by a team of specialists from Valmet working with mill personnel to conduct an audit and performance review of the machine and stock preparation systems. The audit identified which of the existing structures and components could be reused and which were in need of repair. Maintenance and replacement recommendations were also agreed to help avoid unplanned shutdowns and enhance the efficiency and runnability of the machine. Based on the final report presented to the mill, Valmet was selected to rebuild the refining line, wire and drying section of PM 9 and to supply the automation and engineering.

Proven expertise

The production of semi-extensible sack paper relies on good stock preparation to provide the exceptional combination of strength and porosity needed in the final product. High-consistency refining is the answer, creating micro-compressed curly fibers that result in higher stretch and tensile energy absorption values. An RGP 262 refiner fed by a TRPW-1532 twin roll dewatering press provided the best solution. The mill already had good experience of a similar arrangement using an earlier generation of twin roll press in the PM 10 rebuild. Valmet also supplied a new seal water unit and broke thickener, together with auxiliary equipment such as pumps, field instruments, manual and automatic valves, piping, tanks and agitators to complete the stock preparation modernization. Erection supervision, start-up assistance and operator training were included in the delivery.



Figure 10. An RGP 262 refiner fed by a TRPW-1532 twin roll dewatering press provided good stock preparation before the Valmet Breast Roll Shaker unit.

The modernization of the paper machine included a Valmet Breast Roll Shaker breast roll shaker and a rebuild of the dryer section to improve drying capacity and moisture profiles. Valmet Breast Roll Shaker improves formation as it shakes the breast roll in a CD direction and breaks unwanted flocks by creating shear forces on the web. Based on the good results with PM 9, the mill ordered a second Valmet Breast Roll Shaker for PM 10.

Installation

The rebuild operations of PM 9 commenced and went according to the schedule. "A complete mutual understanding was reached between the project managers. All questions were solved promptly. The erection supervisors Hannu Lipsanen and Jaakko Lattu were always ready to provide any advice and assistance to our installation contractor specialists. There was a businesslike and well-intentioned atmosphere at the erection site," explains Aleksander Sivkov, Project Manager. In June 2008, PM 9 was restarted with the production of semi-extensible sack kraft paper.

Results

The investment focused on increasing the mill's competitiveness in international markets. The immediate results were impressive, and the quality properties specified in the contract were achieved straight away after the start-up. "Now we mainly concentrate on exports. Deliveries to Europe have increased," says Vladimir Ermakov.

"The quality improvement was evident after the first stage of the rebuild. It is especially obvious on the standard paper," explains Zinaida Pugina, PM 9 and PM 10 Stock Preparation Manager.

"Now we can produce both paper and board with a basis weight range of 50-125 g/m² thanks to the rebuild of the wire and drying section equipment of the PM 9," says Vladimir Ermakov. "Now it is possible to say that the first stage rebuild goals have been met. No one else in Russia is producing such good-quality sack paper which is also highly rated in Europe. We haven't had any quality complaints from our customers. Such successful results have been possible due to Valmet's equipment and technology!"

Recognized for quality

The award ceremony for winners of "The Best Exporter of 2008" competition was held in Moscow on June 3, 2009, by the Ministry of Foreign Affairs of the Russian Federation. Among the 56 winners, the Segezha Pulp and Paper Plant, Inc., (InvestLesProm Group) was awarded with the prize for the best exporter in the industry (pulp and paper industry).

Summary

In conclusion, Valmet Breast Roll Shaker improves the sheet forming process by shaking the breast roll cross-directionally and breaking up fiber flocks by creating shear forces on the web. The system improves sheet formation, and strength and visual properties.

Valmet Breast Roll Shaker is very easy to use and maintain, with a compact integrated design. It is proven technology with many references across several grades. Results on board machines show an average formation improvement of 15%. Most recently, a North American reference has seen a 20% improvement in formation with a corresponding 11% gain in bottom side smoothness.



Figure 11. Valmet Breast Roll Shaker provides the ability to optimize furnish.

This white paper combines technical information obtained from Valmet personnel and published Valmet articles and papers.

Valmet provides competitive technologies and services to the pulp, energy and paper industries. Valmet's pulp, paper and power professionals specialize in processes, machinery, equipment, services, paper machine clothing and filter fabrics. Our offering and experience cover the entire process life cycle including new production lines, rebuilds and services.

We are committed to moving our customers' performance forward.